

 GÖTESSONS







EVERYTHING EXPECT FOR THE TABLE & STORAGE...



# OFFICE NAP



# GOTESSONS

*by*AM Acoustics

WOODSTOCK



byAM Acoustics



WOODSTOCK





byAM Acoustics

byAM Acoustics









*by*AM Acoustics

*by*AM Acoustics



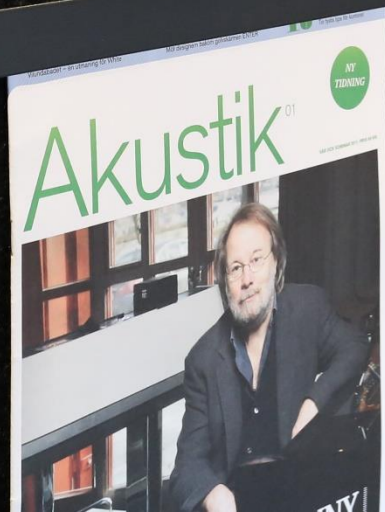





*by*AM Acoustics





byAM Acoustics







LOD ACOUSTIC

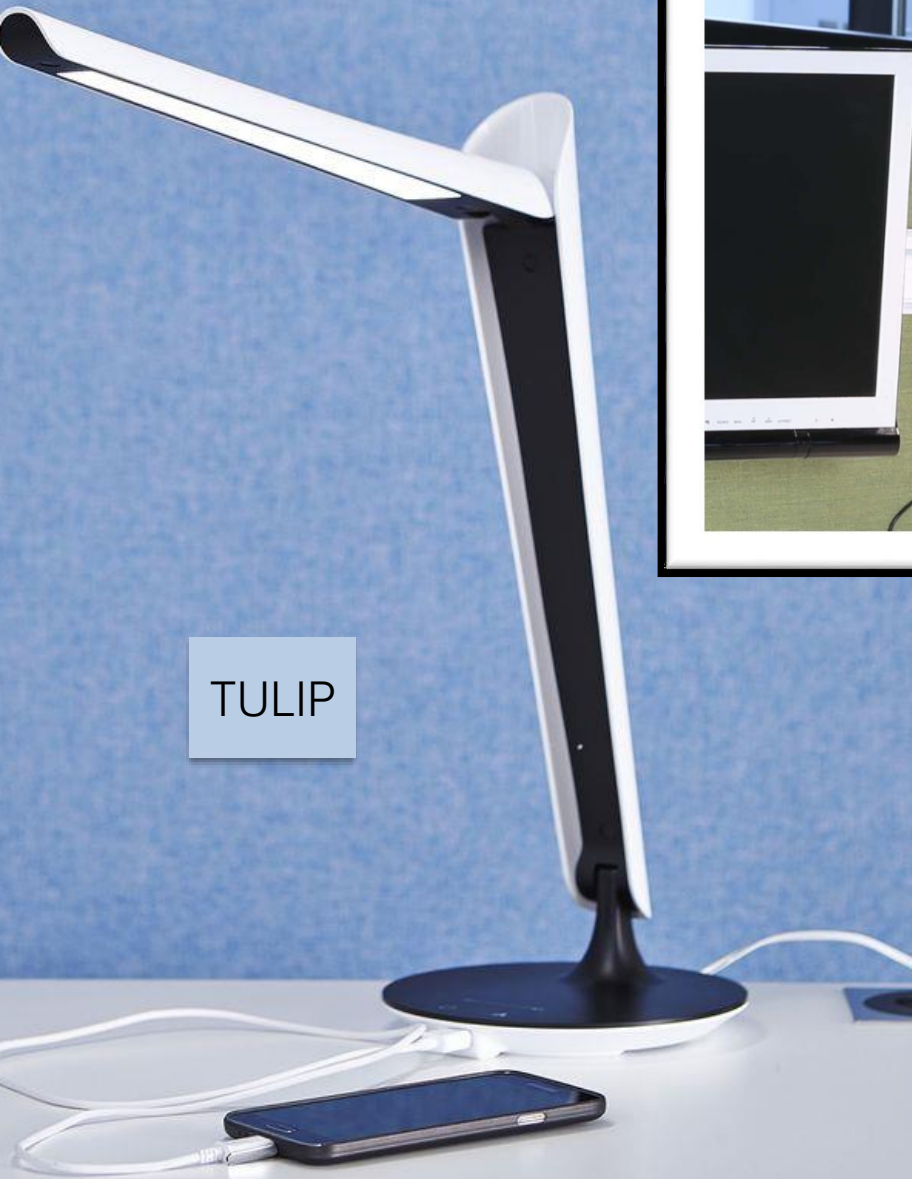

TULIP





THE LIGHTNING

## SILENT PENDANT LAMPS





## YOGA-MAT STANDZONE





3 NEW STANDZONE





# MONITOR ARMS

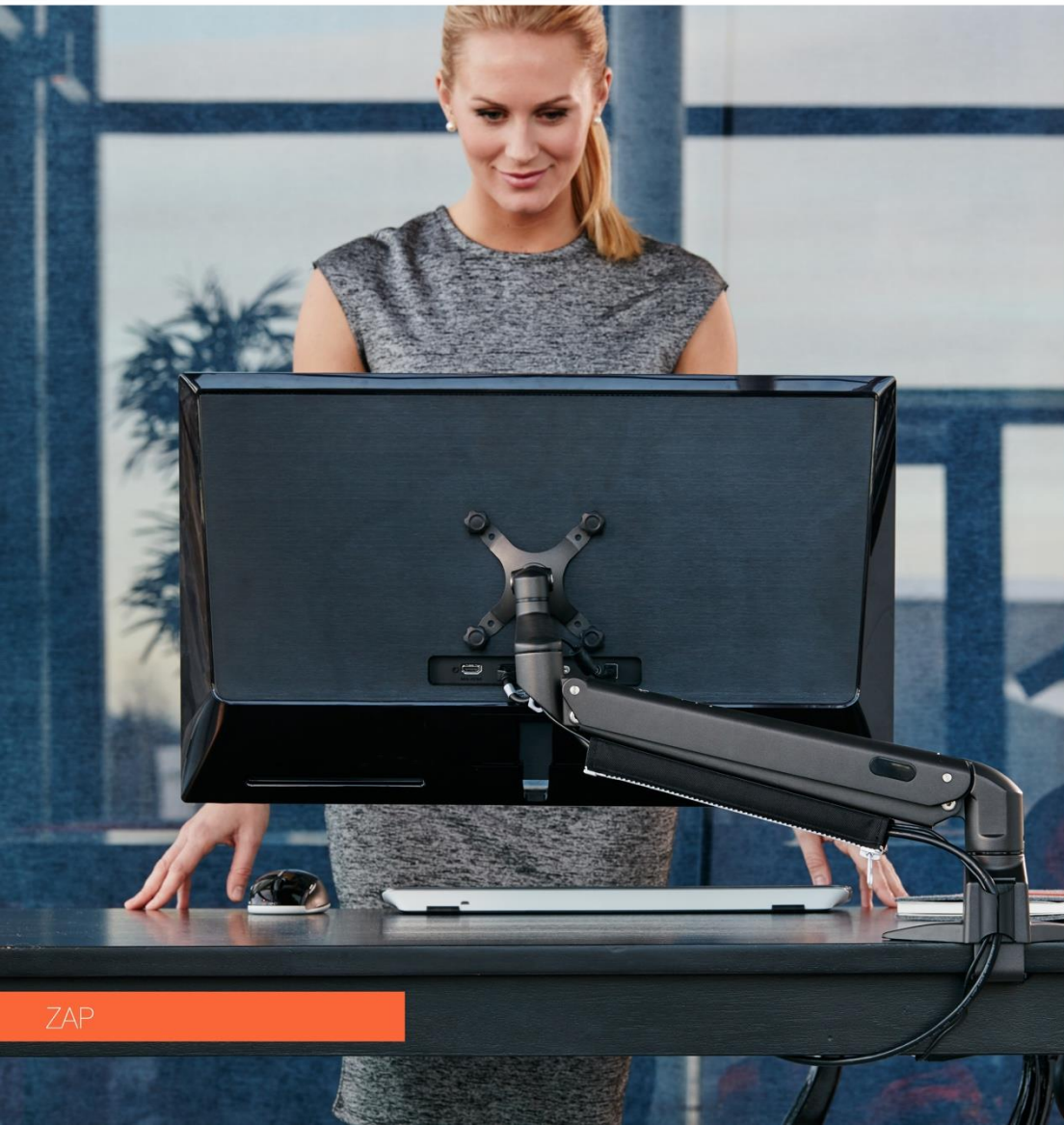

ZAP

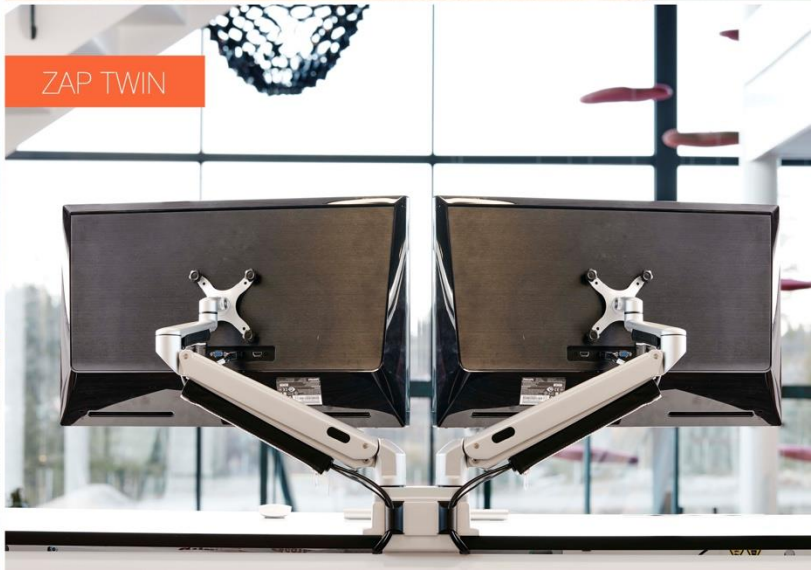

ZAP TWIN

V4



V4 Twin



# CABLE MANAGEMENT



CABLE COLLECTOR



SETUPIT



POWER GROMMET



ZAP



HALFPIPE



# ELECTRICAL ACCESSORIES

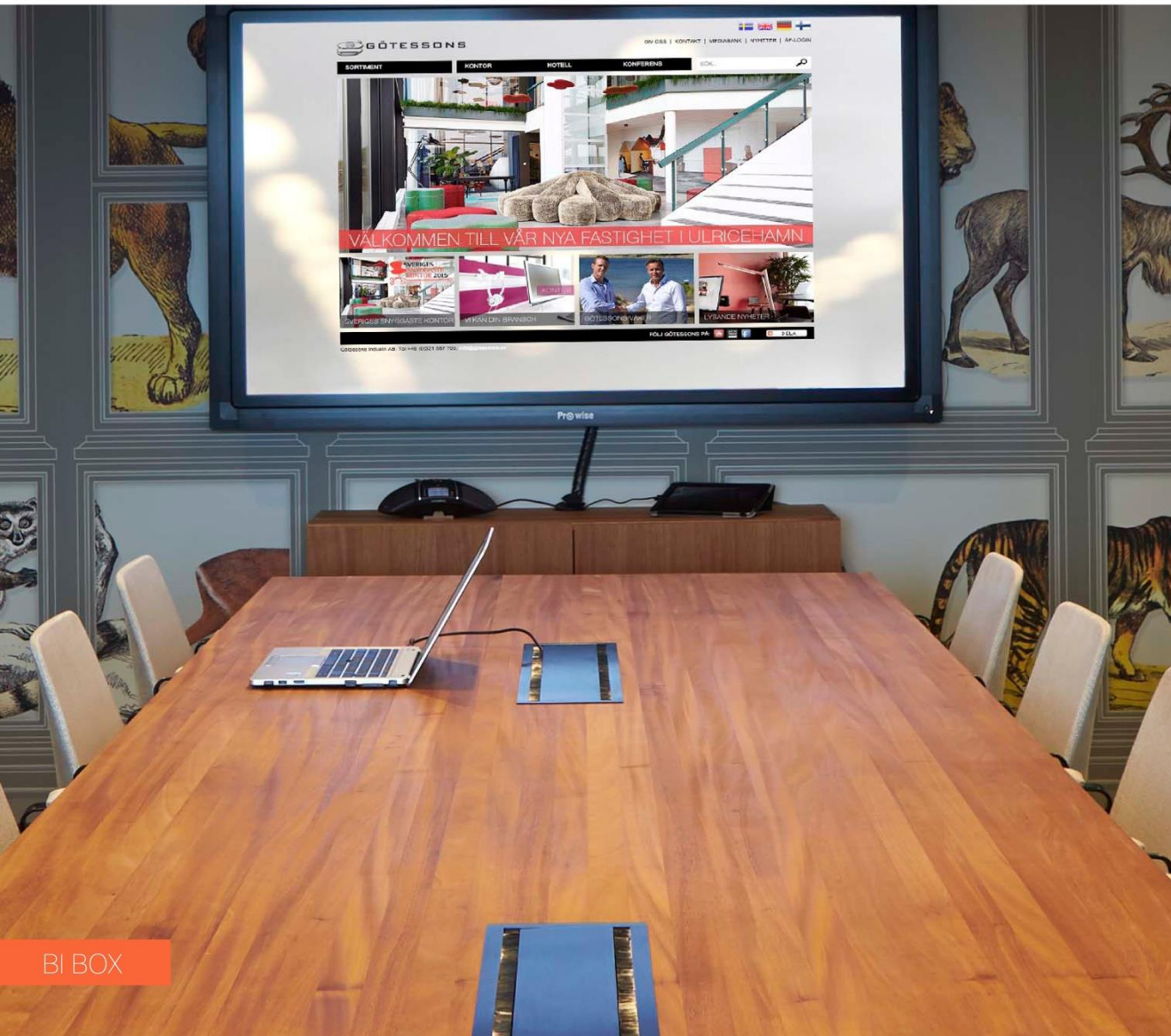

BI BOX



POWER INLAY



GST 18

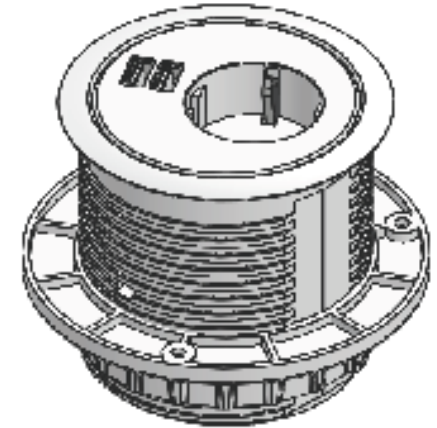
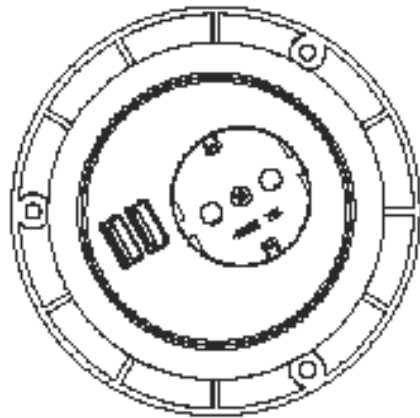
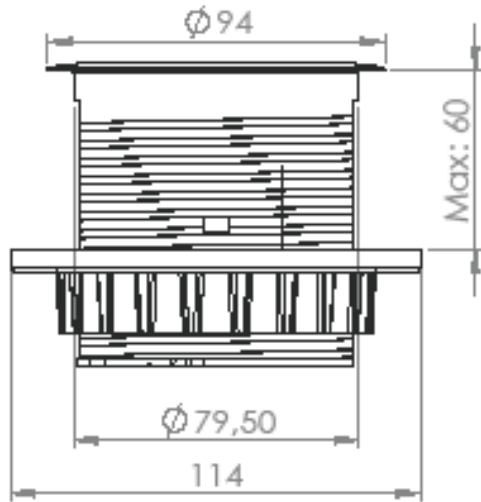

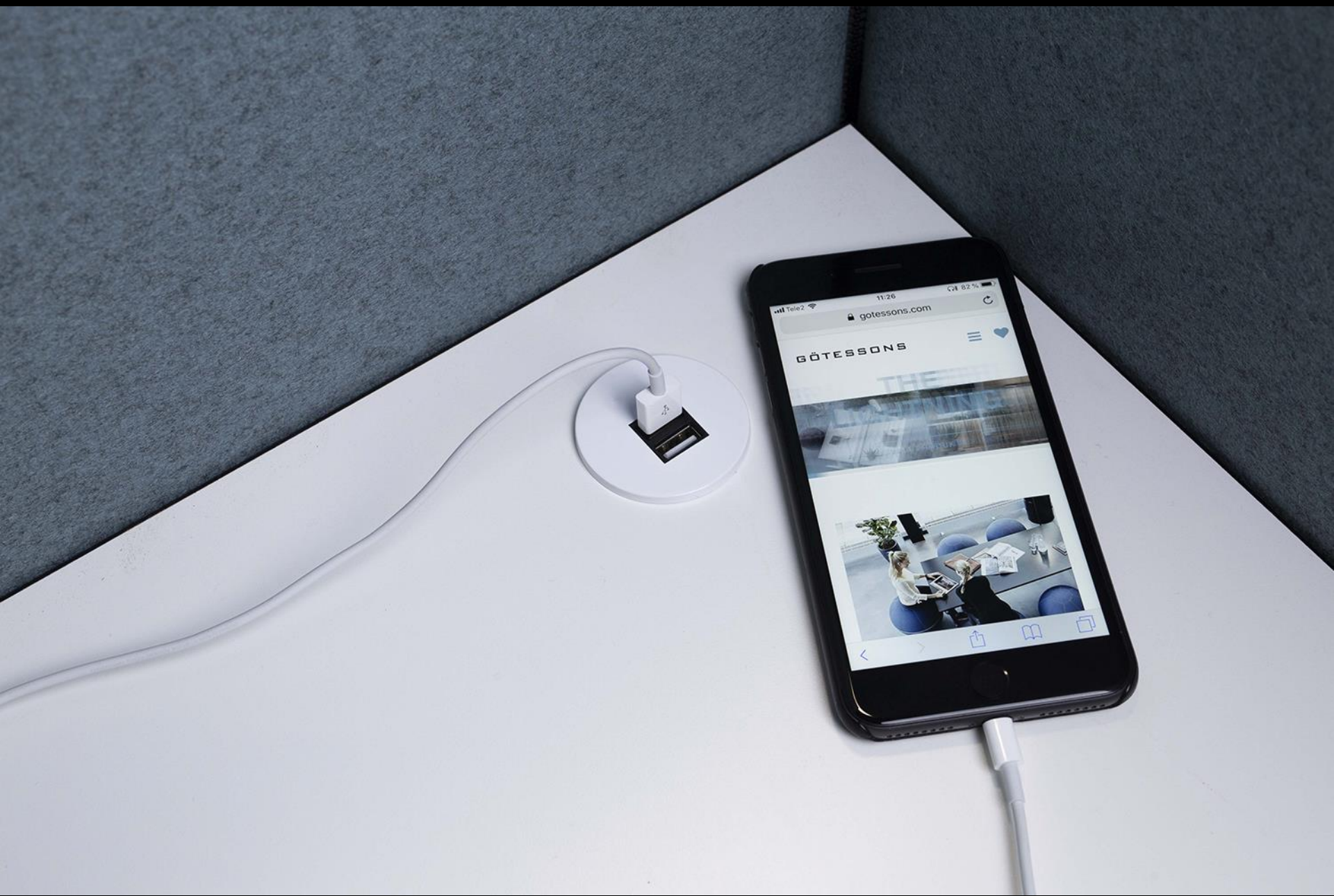

Table cut out: Ø80mm

		<b>GÖTESSONS</b>		
Art.nr: 721500		Name: Max Power Grommet 1 power, 2 USB charging		
Last saved by: Jonathan	Last saved: 2018-11-07	Material: x	Rev: -	Format: A4
Created by: Jonathan	Created date: 2018-11-02		Scale: 1:2	Page: 1/1



11:26 82%  
gotessons.com

GÖTESSONS



# PLANTS

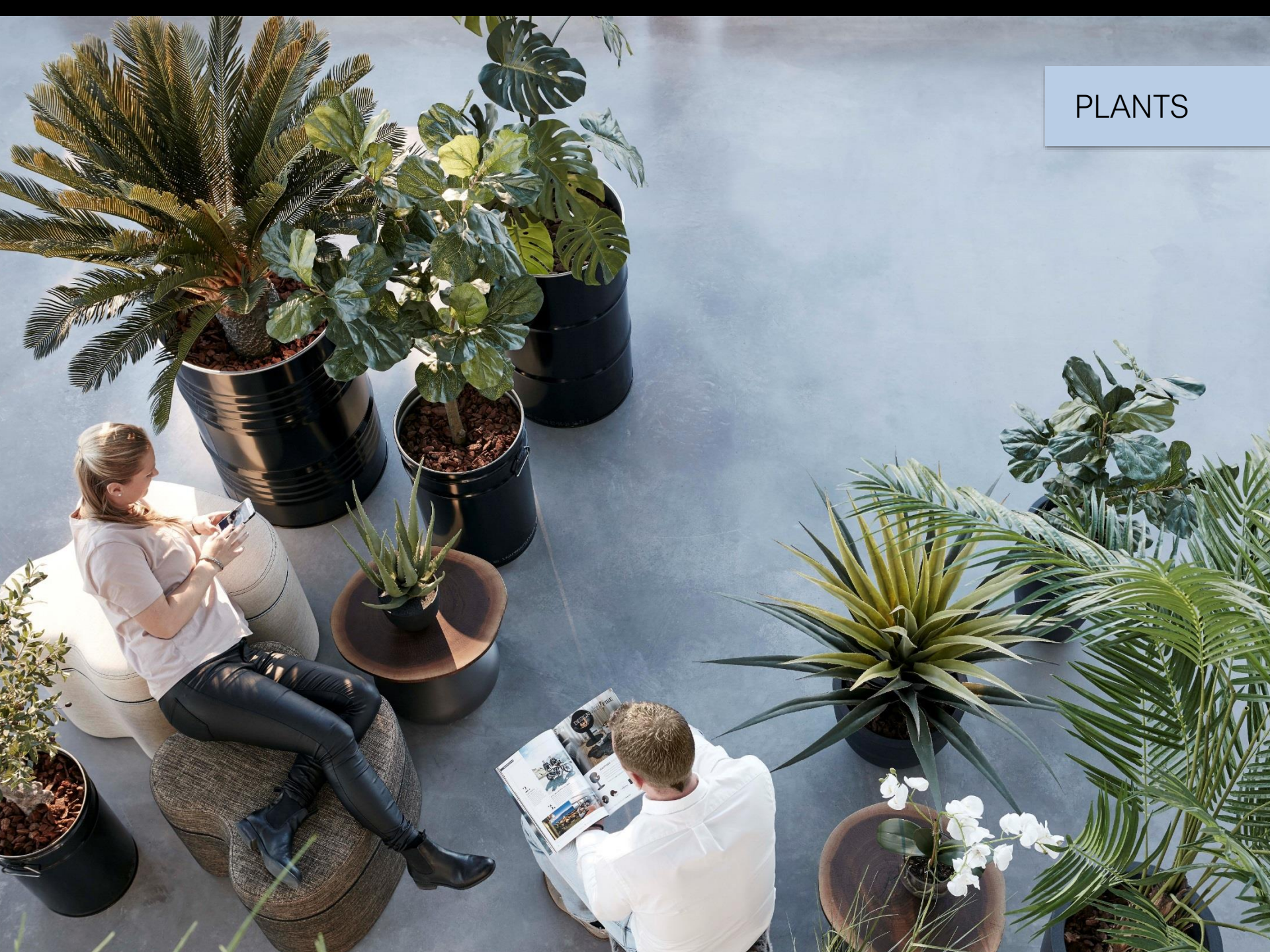

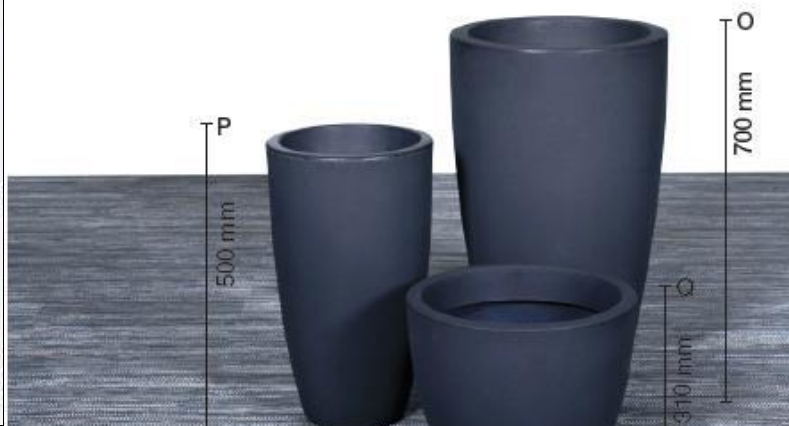
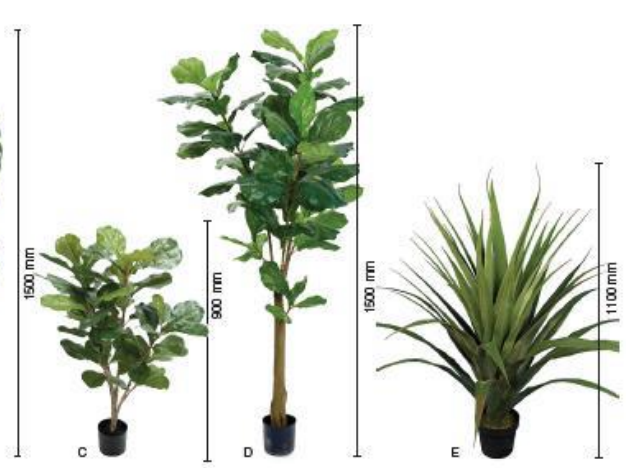

# NEW PLANTS & POTS



## A30 WHITEBOARD



## SCREENIT REINFORCED STANDARD







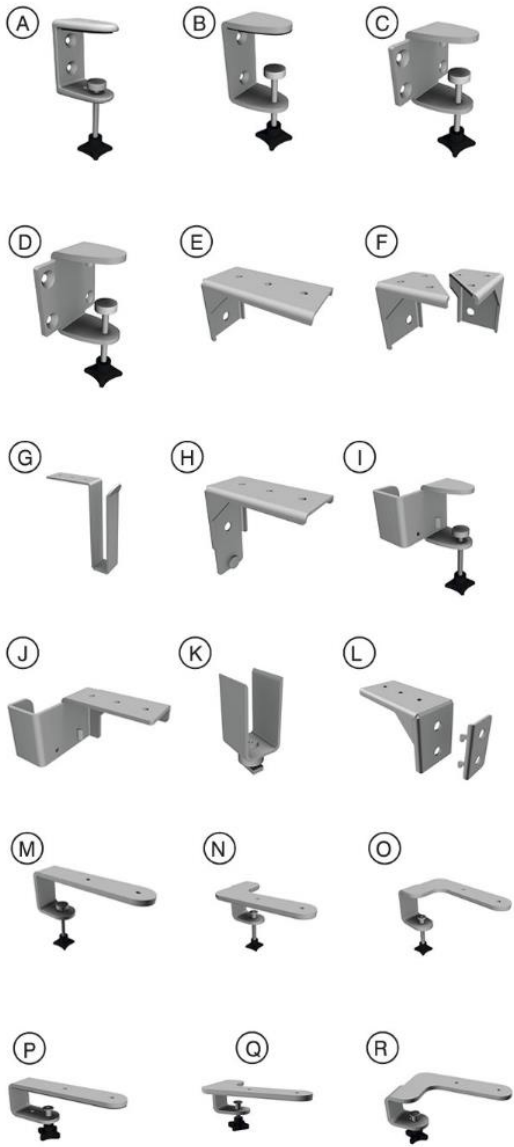

## MOUNTS

Art.No Size/Description Colour  
(all dimensions in mm)

- A** Clamp set for desk screen  
For up to 42 mm desks. 2 pcs in one pack.  
641010-1 white -2 black -3 silver
- B** Clamp set for desk screen  
For up to 72 mm desks. 2 pcs in one pack.  
641025-1 white -2 black -3 silver
- C** Corner clamp set for A30 desk screen  
For clamping side and frontal screens at 90°. For 42 mm desks.  
2 pcs in one pack.  
641050-1 white -2 black -3 silver
- D** Corner clamp set for A30 desk screen  
For clamping side and frontal screens at 90°. For 72 mm desks.  
2 pcs in one pack.  
641045-1 white -2 black -3 silver
- E** Desk mount set for desk screen  
To be mounted with screws under the desk. 2 pcs in one pack.  
641020-1 white -2 black -3 silver
- F** Corner mount set for A30 desk screen  
For mounting side and frontal screens at 90°. 2 pcs in one pack.  
641058-1 white -2 black -3 silver
- G** Desk mount set Slide-in  
2 pcs in one pack.  
641085-1 white, 2 black, 3 silver
- H** Desk mount set for Halfpipe with keyhole  
To be mounted with screws under the desk. 2 pcs in one pack.  
642065-1 white -3 silver
- I** Desk clamp adjustable for screens without holes  
2 pcs in one pack. For up to 42 mm desks.  
642032-1 white -2 black -3 silver
- J** Desk mount adjustable for screens without holes  
Not possible to use 2 mounts in the same angle. 2 pcs in one pack.  
642033-1 white -2 black -3 silver
- K** Clamp for desk with aluminium rail  
2 pcs in one pack.  
642062-1 white -2 black -3 silver
- L** On/Off Desk mount  
To hook on and off. 2 pcs in one pack.  
642077-1 white -2 black -3 silver
- M** Desk clamp for ScreenIT A30 Sidescreen  
For up to 42 mm desks. 1 clamp included.  
642068-1 white -2 black -3 silver
- N** Desk clamp right for ScreenIT A30 Sidescreen  
For up to 42 mm desks. 1 clamp included.  
642082-1 white -2 black -3 silver
- O** Desk clamp left for ScreenIT A30 Sidescreen  
For up to 42 mm desks. 1 clamp included.  
642083-1 white -2 black -3 silver
- P** Desk clamp Small for ScreenIT A30 Sidescreen  
For up to 27 mm desks. 1 clamp included.  
643011-1 white -2 black -3 silver
- Q** Desk clamp Small right for ScreenIT A30 Sidescreen  
For up to 27 mm desks. 1 clamp included.  
643012-1 white -2 black -3 silver
- R** Desk clamp Small left for ScreenIT A30 Sidescreen  
For up to 27 mm desks. 1 clamp included.  
643013-1 white -2 black -3 silver

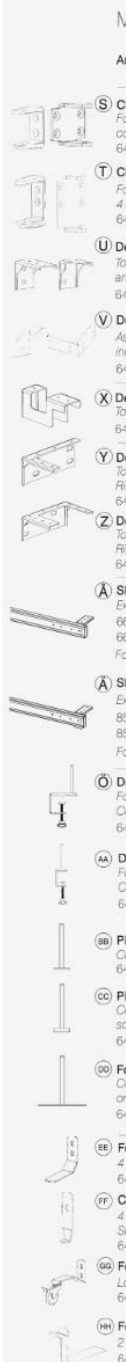
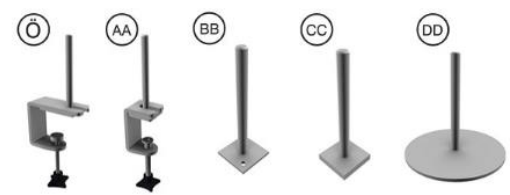
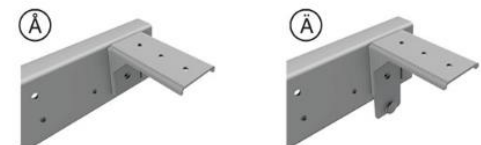

# SCREENIT A30 ECO LABELED BY THE NORDIC SWAN



A30 FLEXIBLE



A30 SLIDE



A30 DESK SCREEN

# TOWER BOOTH

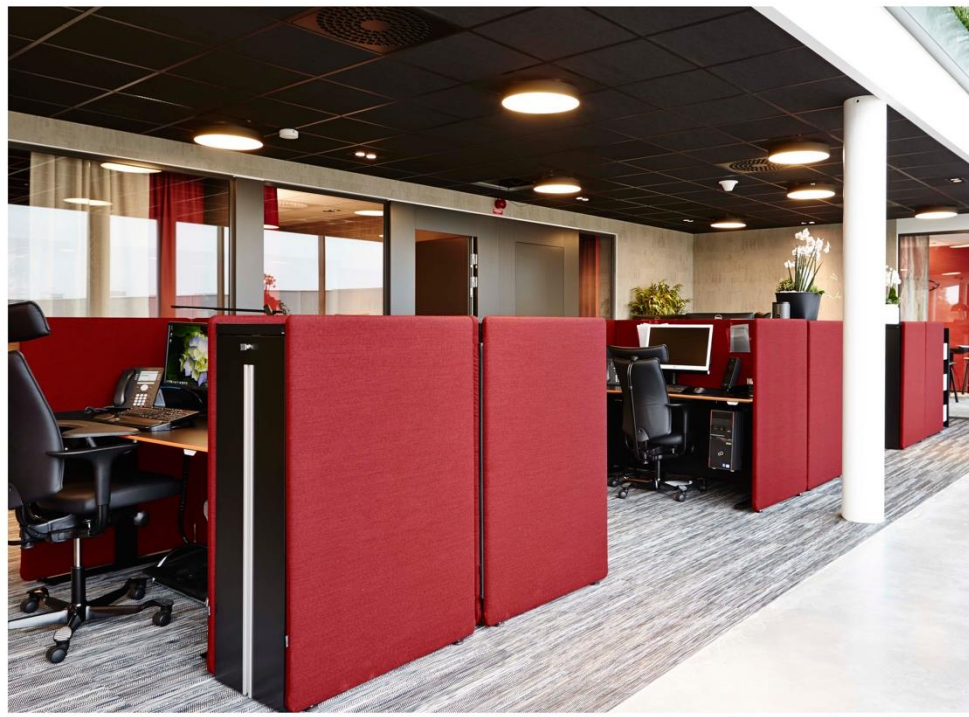

ZIPPABLE WORK BOOTH WITH ADJUSTABLE HEELS

A30 PEAK DESIGN BOOTH







# THE HUT COLLECTION

The house's simple and straight lines are inspired by the classic game of Monopoly and its game pieces that give a timeless shape to the popular and practical "room-in-room" concept.

The house can be used for several purposes; as an individual workstation, a small sit-and-stand meeting room or as relax areas combined with The Hut Sofa. New for this year is that The Hut has a door in plexi. Everything to do it even more personally and shut out the sounds from outside and close in what is said in the house. Designed by Workspace Finland and manufactured by Gotessons. Contact us for details of the new The Hut Sofa and other Hut extras.



## THE HUT

Art.No Size/Description  
(all dimensions in mm)

### THE HUT

The Hut  
110180

The Hut with cable channel  
110280

Out. meas: W:1880 H:2270 D:1870  
In. meas: W:1790 H:2220 D:1790  
For all measures see [www.gotessons.com](http://www.gotessons.com).

### THE HUT WITH FRONT SCREENS

The Hut  
110700

The Hut with cable channel  
110800

Out. meas: W:1880 H:2270 D:1870  
In. meas: W:1790 H:2220 D:1790  
For all measures see [www.gotessons.com](http://www.gotessons.com).

See price ranges on page 8-11.

Art.No Size/Description  
(all dimensions in mm)

### THE HUT WITH FRONT SCREENS AND DOOR

The Hut  
110500

The Hut with cable channel  
110600

Out. meas: W:1880 H:2270 D:1870  
In. meas: W:1790 H:2220 D:1790  
For all measures see [www.gotessons.com](http://www.gotessons.com).

Info: Prices is with the same textile on both sides.  
If you want different combination of textiles, please contact us for prices.

### The Hut Lamp

5 m black textile cord with a copper base and black switch. LED lamp included.  
821020

### Whiteboard The Hut

Magnetic whiteboard for The Hut and Half a Hut.  
648110 W:1100 H:900





# EXTENDED RANGE OF THE HUT FAMILY











# THE HUT LOUNGE





# THE HUT LOUNGE

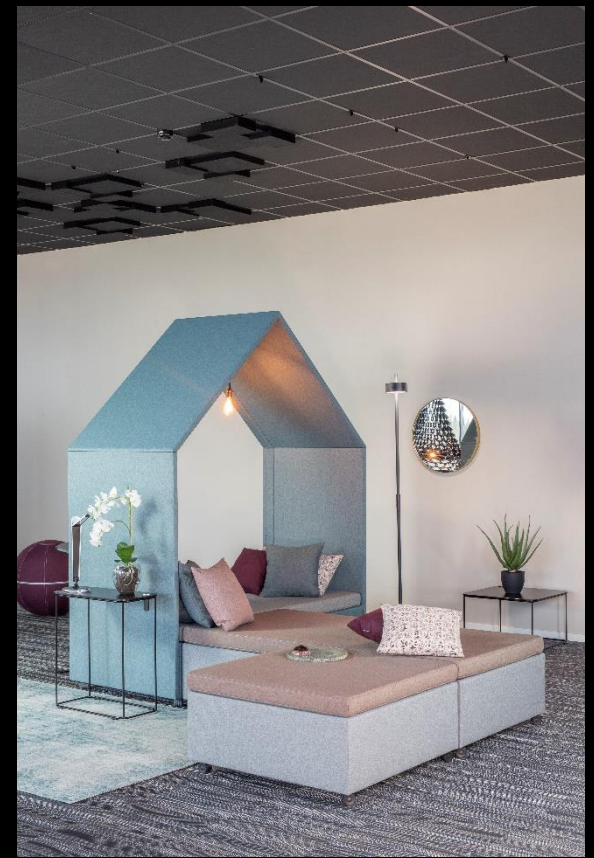











- The Hut Lounge Collection
- Cushions
- Monitor arm V4
- Cable management
- The Lightning, down- and uplight
- Plants and Pots
- Ergonomic Office Ballz
- Table Top power outlet
- SMS-Box with lid for storage

Today Gotessons offers a wide range of products for offices and public areas...

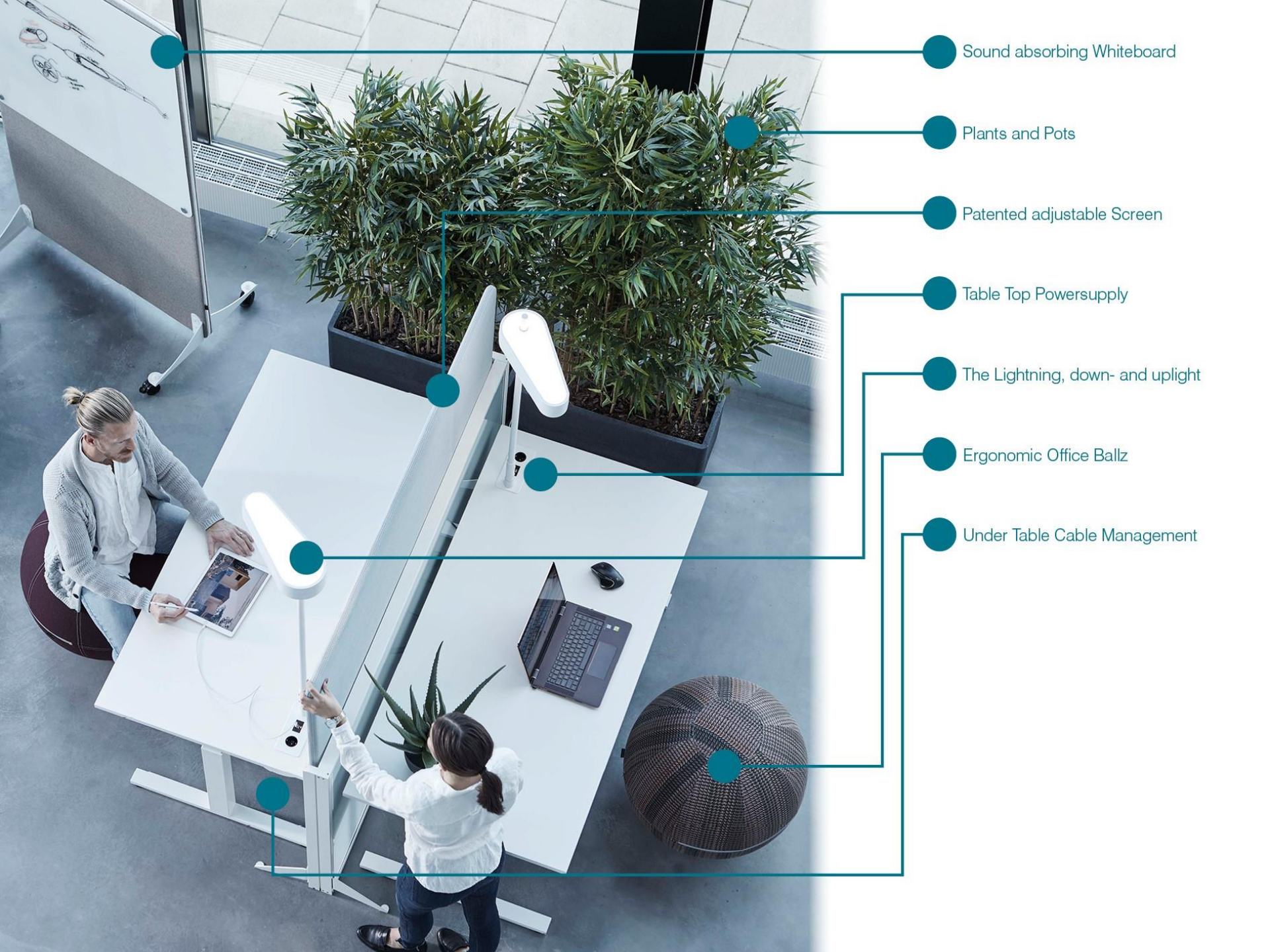

Sound absorbing Whiteboard

Plants and Pots

Patented adjustable Screen

Table Top Powersupply

The Lightning, down- and uplight

Ergonomic Office Ballz

Under Table Cable Management

# P-CON



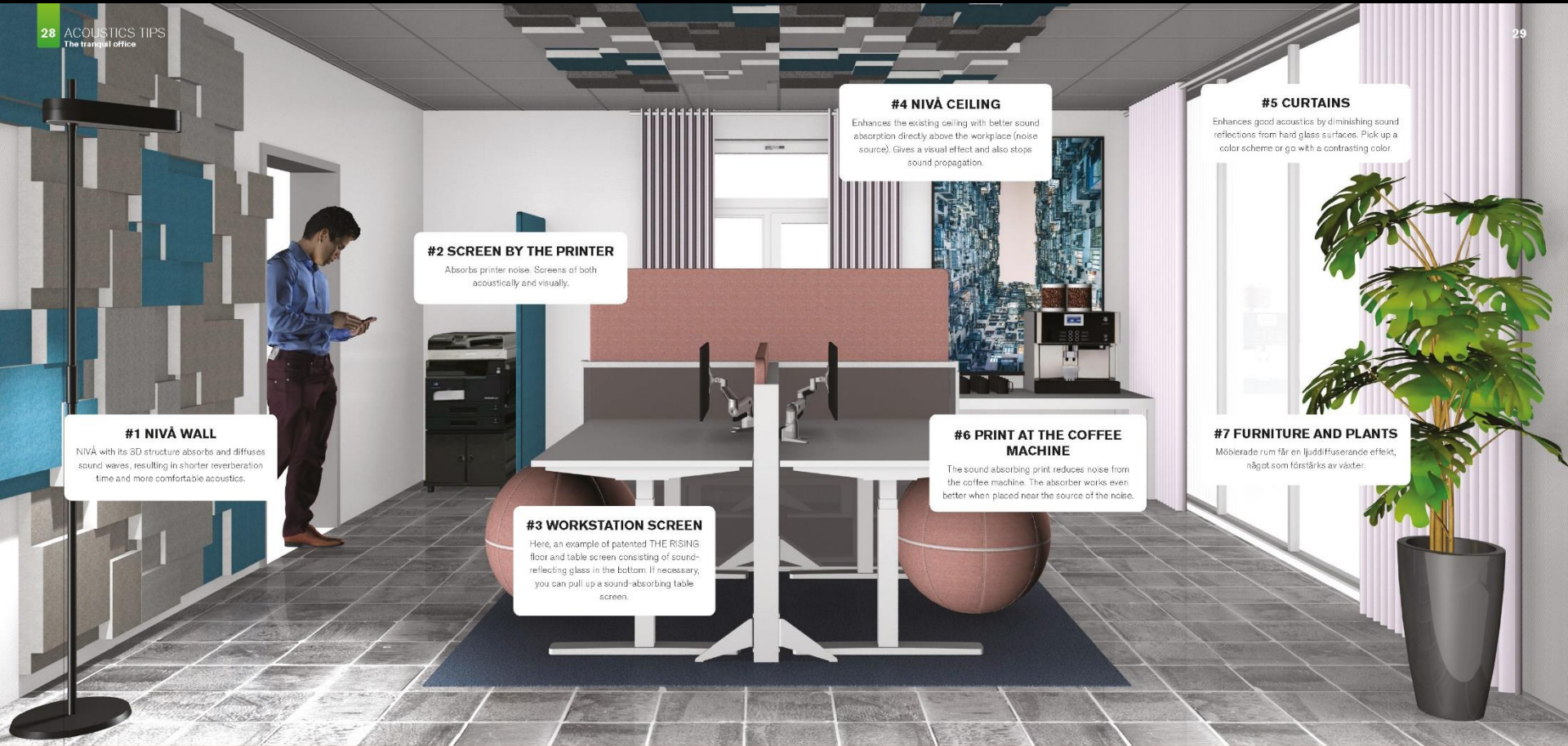

**#1 NIVÁ WALL**

NIVÁ with its 3D structure absorbs and diffuses sound waves, resulting in shorter reverberation time and more comfortable acoustics.

**#2 SCREEN BY THE PRINTER**

Absorbs printer noise. Screens at both acoustically and visually.

**#3 WORKSTATION SCREEN**

Here, an example of patented THE RISING floor and table screen consisting of sound-reflecting glass in the bottom. If necessary, you can pull up a sound-absorbing table screen.

**#4 NIVÁ CEILING**

Enhances the existing ceiling with better sound absorption directly above the workplace (noise source). Gives a visual effect and also stops sound propagation.

**#6 PRINT AT THE COFFEE MACHINE**

The sound absorbing print reduces noise from the coffee machine. The absorber works even better when placed near the source of the noise.

**#5 CURTAINS**

Enhances good acoustics by diminishing sound reflections from hard glass surfaces. Pick up a color scheme or go with a contrasting color.

**#7 FURNITURE AND PLANTS**

Möblerade rum får en ljuddiffuserande effekt, något som förstärks av växter.

**ACOUSTICS – HOW IT WORKS**

Reverberation time is defined by how long it takes for a sound to become inaudible. Long reverberation time can be disturbing and makes it difficult to perceive speech and maintain concentration, which causes stress. At Gotessons and A.M. Acoustics, we often work with premises such as offices, schools, restaurants, where short reverberation of about 0.5 seconds is desirable.

**Absorption**

Sound absorbers slow down sound waves, resulting in shorter reverberation times. Wall and ceiling solutions are most common since they can cover large areas of a room. The large areas are supplemented with locally placed sound absorbers, ideally close to the source of the noise, such as a sound absorbing print on the wall of a conference room. [See article about TV-studio absorbers.](#)

**Reflection**

Hard surfaces like glass reflect sound. Acoustics can use this in concert venues where you do not want to use electric amplification, and when you want to reduce noise by blocking it. [See tip #5 about glass top under the desk screen.](#)

**Transmission**

An important part of acoustics design is so-called audio transmission that determines how sound passes through the roofs and walls of a building. Good wall and ceiling absorbers help reduce transmission so that unwanted noise does not spread from room to room. [See article about the info in Freskan which got absorbers specially mounted for reduced transmission.](#)

**Diffraction**

Sound waves crouch around objects that "stand in the way", a physical phenomenon that sound share with other types of waves. Low hertz sound waves bend more than short. For example, outside a nightclub you will hear mostly bass sounds. Take into account the diffraction when you in an office landscape want to create different zones, some quieter than others. Use multiple screens in a row to minimize diffraction.

**Diffusion**

A diffuser breaks up the sound and reflects it in different directions. Correctly placed in the room, the sound quality will improve while reducing the reverberation time. [See tip #7 about furniture and plants.](#)

**THE TOOLS**

**pCon Planner**

Free 3D program for creating rooms and environments where all products from Gotessons and A.M. Acoustics are included. The program also has an AR-app (Augmented reality). In camera mode on your phone/pad, you can see how your room turned out "in reality". [Read more on pcon-planner.com.](#)

**Acoustic Facts**

Get started by describing your room on the web service. Then place products in the room from Gotessons and A.M. Acoustics as well as other suppliers. The system calculates the acoustics properties of the room prior to assembly.



FURNISH YOUR PROJECTS –

GOTESSONS *NOW ON* BIMobjects

**GOTESSONS**

[WWW.BIMOBJECT.COM/EN/GOTESSONS](http://WWW.BIMOBJECT.COM/EN/GOTESSONS)

**bim**  
**object**<sup>®</sup>





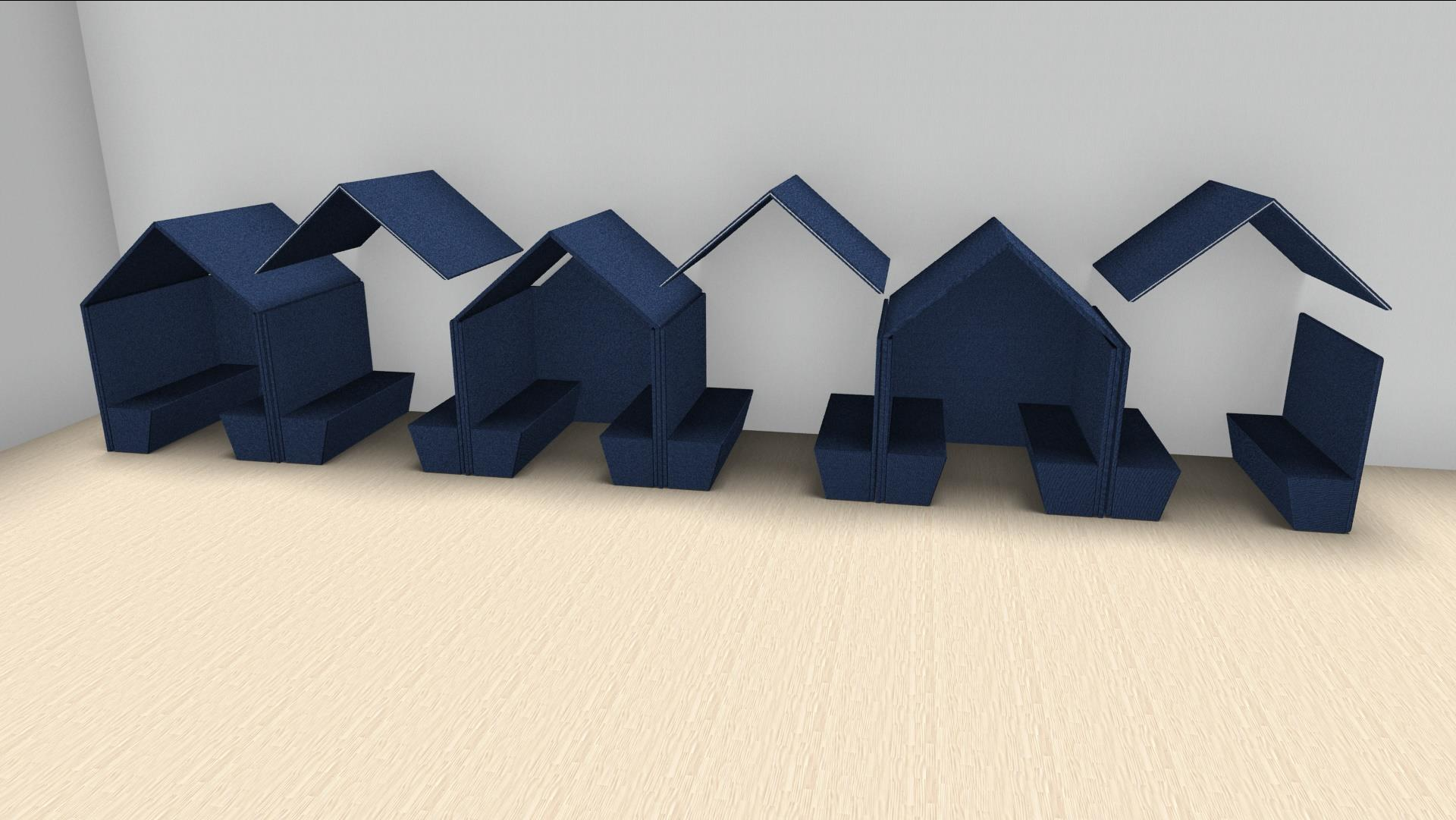







**IN-HOUSE** made for project request



WE CAN HELP



# Acoustic problems? WE CAN HELP

Do you want help calculating the acoustic values in a certain Space or room and how to get them down to acceptable levels?

With a few basic information measurements of the room in question we calculate the original reverberation time and with suggested acoustic ceiling, wall and screen products help recommend you and your client the products and quantity amount needed for a better sound.

See ten golden tips on page two.

Room/Project Name			
Furnished	densely	sparsely	
Determines the amount of furniture in the room. Choose <b>Densely</b> if it is furnished in a tight or normal manner (as at home or classrooms), and choose <b>Sparsely</b> if furniture is sparse (as in lobbies or entrance halls)			
Ceiling	light	heavy	
Construction type for ceiling, can be a light or heavy construction. <b>Light:</b> Plasterboards, wooden plates etc. <b>Heavy:</b> Concrete, brick or stone. Choose <b>Heavy</b> if the construction is unknown, as this gives no overestimation of the amount of absorption in the room.			
Wall 1 (m)	height	length	light
Wall 2 (m)		length	heavy
Product Name Preference			
Product Type	Ceiling Acoustic	Wall Acoustic	Screen Acoustic

To register in to the calculation site and see all products.

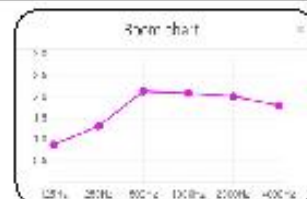

**GÖTESSONS**

Göteborgs Industri AB, Rönnelegatan 5B, 523 38 Ulricehamn SWEDEN  
Tel. +46 (0)321-687700, info@gotessons.se, www.gotessons.com

**akustikmiljö**

Akustikmiljö i Falkenberg AB, Falkåvövägen 5, 31121 Falkenberg SWEDEN  
Tel. +46 (0)346-714850, info@akustikmiljo.se, www.akustikmiljo.com

<https://youtu.be/YQbZCn2czq0>

2019-04-10 Products in the room | Acoustic Facts **acoustic facts**

Room Name	Project Name	Volume (m3)
1C2.2	Elan Interior	177.48

Reverberation Time Original	Reverberation Time Current
2.29	0.50

### Result Graph

**Original**

Frequency (Hz)	Reverberation Time (s)
125	2.9
250	2.5
500	2.4
1000	2.3
2000	2.1
4000	2.0

**Current**

Frequency (Hz)	Reverberation Time (s)
125	1.0
250	0.6
500	0.5
1000	0.45
2000	0.45
4000	0.4

### Surfaces

Producer:

Surface Name	Amount
--------------	--------

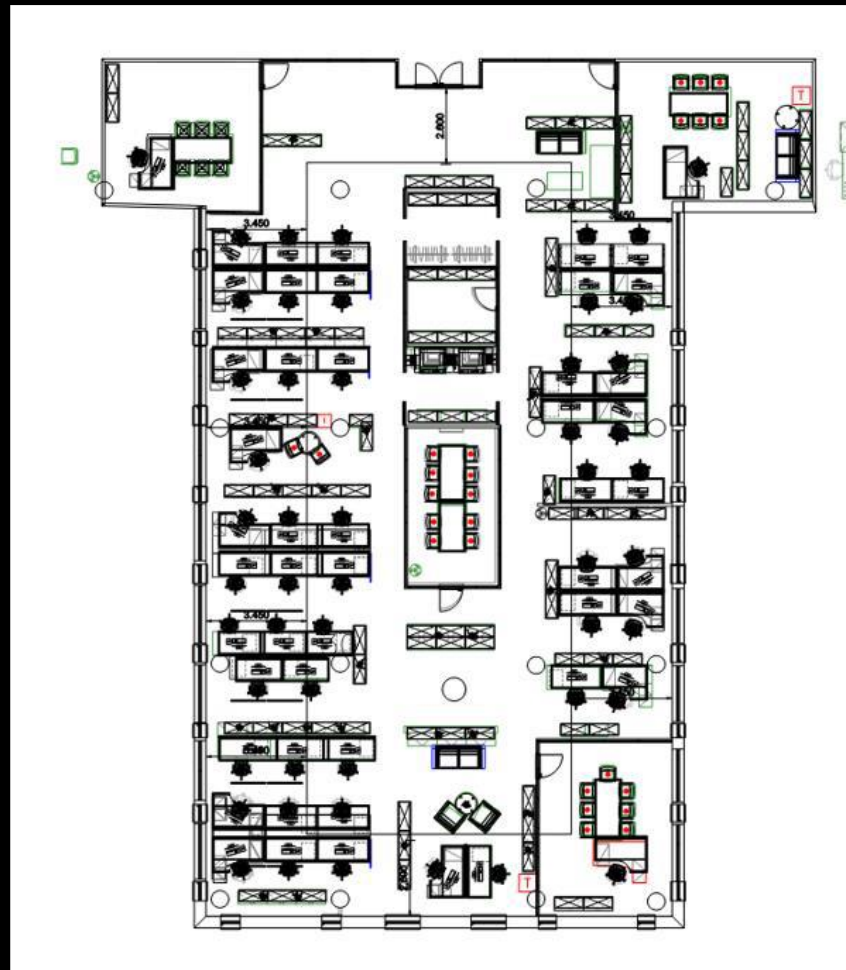

# WE WORK TOGETHER



# REFERENCE 2018



# END CLIENTS

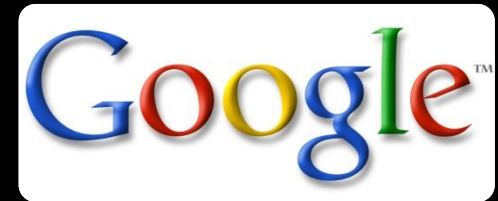



# ACOUSTICS

To reach a good acoustic environment requires knowledge. We work with architects and interior designers to create beautiful environments that are attractive both visually and acoustically, a fancier sound simply. With long experience and personal commitment, we help you through the entire process, from drawing board to finished product.



# ACOUSTIC PRINT BIG



Kosmon  
Eventproduktio





DEN KE...  
KAN DE HITTE



DEN RETTE  
KAN DE HITTE



# ARC / MAGNETIC PRINT





# Barcelona Business School









TV2 BERGEN



TV2 BERGEN



TV2 BERGEN



BREMNES SCHOOL NORWAY

A photograph of a modern library interior. In the foreground, a round white table with black legs is partially visible. Surrounding it are several large, spherical ottomans in various colors: brown, green, yellow, and grey. In the background, there are bookshelves filled with books, a study table with blue chairs, and a large window looking out onto another part of the library. The floor is made of light-colored wood. The overall atmosphere is bright and contemporary.

BREMNES SCHOOL NORWAY





BREMNES SCHOOL NORWAY



BREMNES SCHOOL NORWAY



LOUISE HOFFSTEN, ARGLE BARGLE STUDIO

CAPTECH GÖTEBORG





SWEDISH EXHIBITION & CONGRESS CENTRE



SWEDISH EXHIBITION & CONGRESS CENTRE



SWEDISH EXHIBITION & CONGRESS CENTRE



HORSE STABLE MARLIN CHEVAL





PADELZENTER ÅRSTA & JÖNKÖPING



PADELZENTER ÅRSTA & JÖNKÖPING



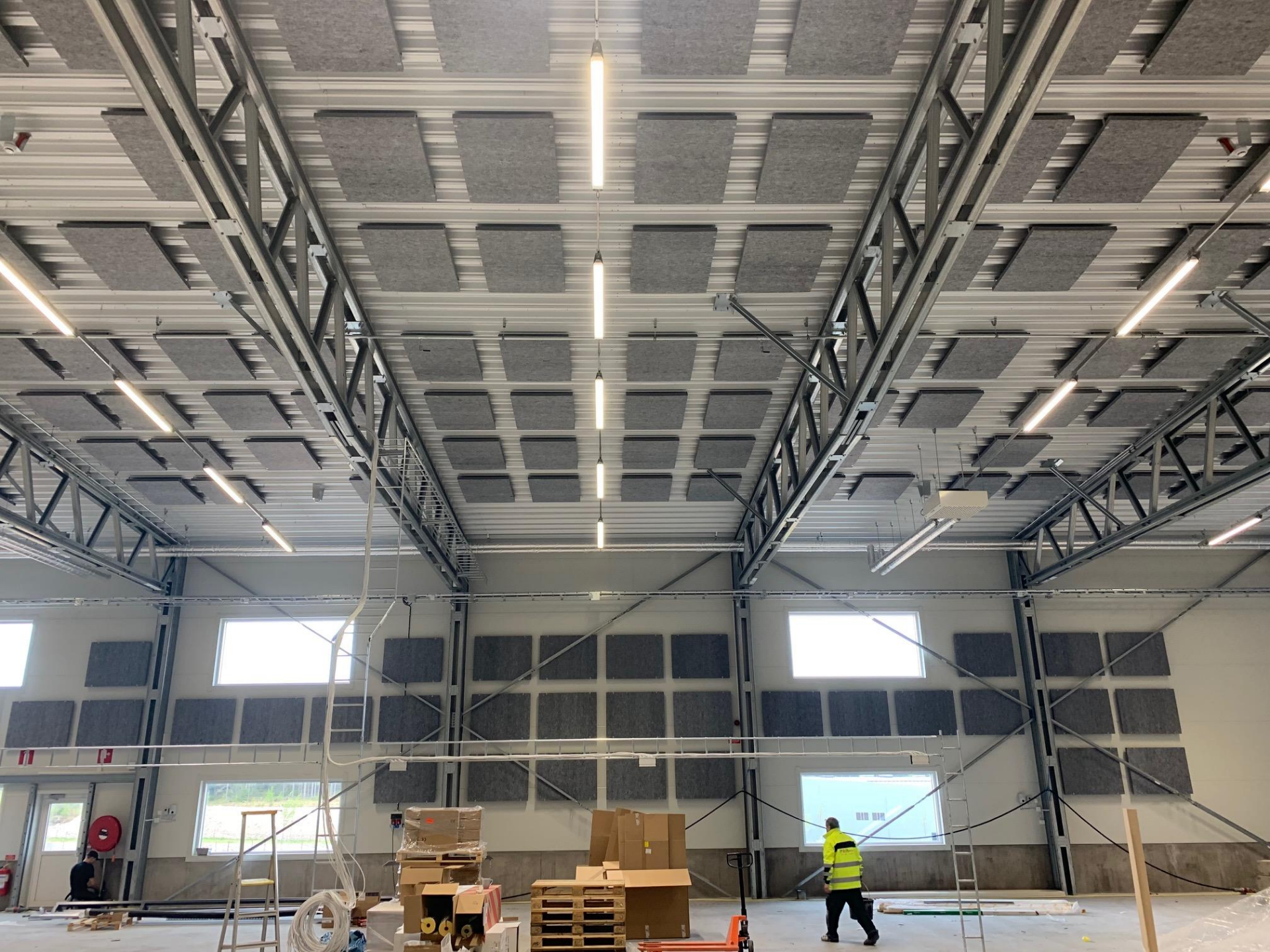





PADDLE CENTER



5

starvie  
BAGEL  
FOUR PRO



PHOTOGALLERY HALMSTAD



PRIVATE HOMES





WORLD CHAMPIONSHIP TABLETENNIS



WORLD CHAMPIONSHIP TABLETENNIS



WORLD CHAMPIONSHIP TABLETENNIS



WORLD CHAMPIONSHIP TABLE TENNIS

C MORE 4



Ny serie baserad på  
Kristina Ohlssons  
kriminalromaner

# S T H L M R E K V I E M

Streama nu på C More  
Premiär onsdag 17 oktober på TV4











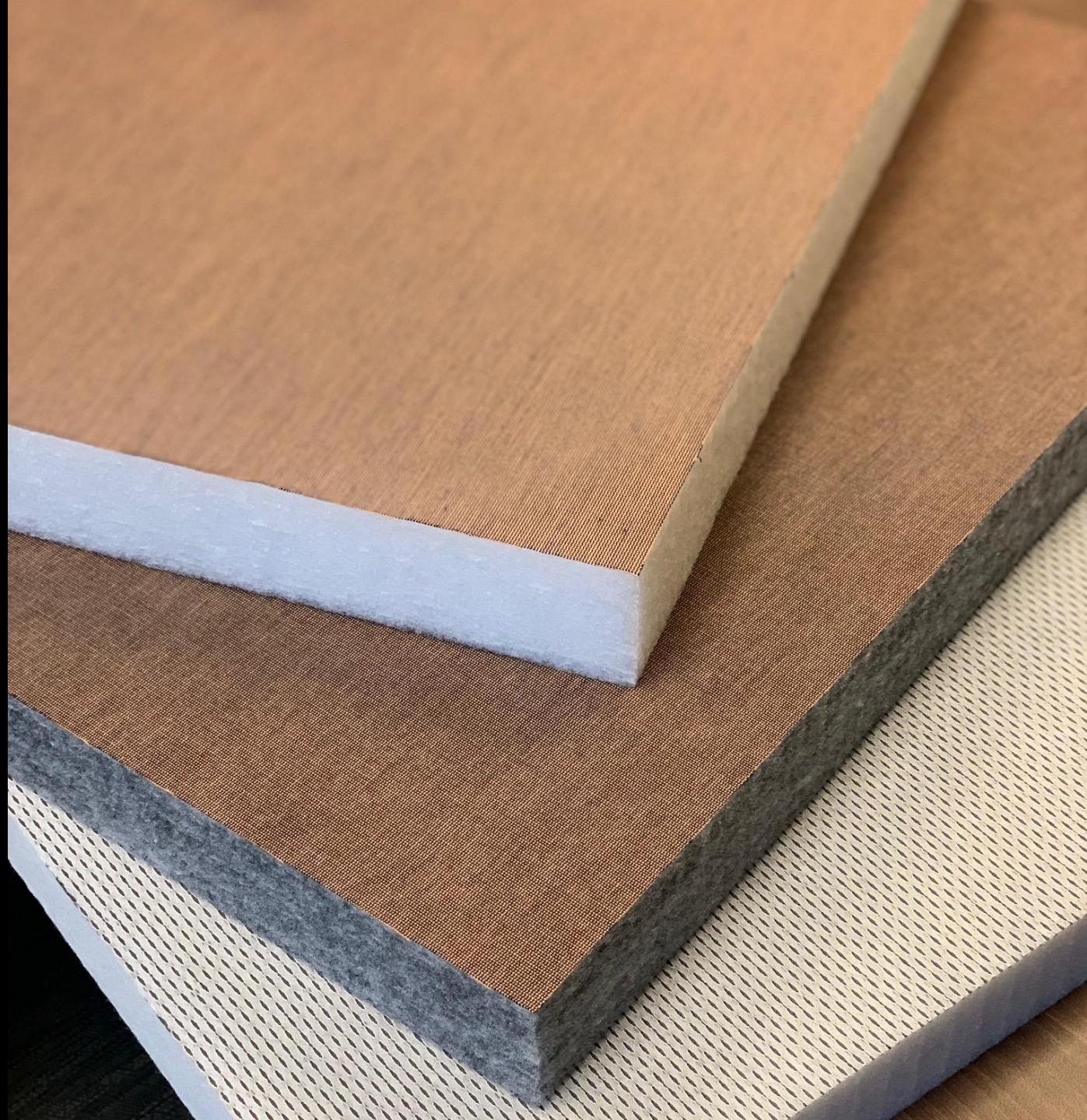



2019



 GÖTESSONS

